

12ICS150

ICS series Intensive Cycle Service

Narada's ICS series battery designed to provide high cycling and fast charge performance, idea for telecom service where power supply is unstable. With innovative structure design, high quality manufacturing and high quality material, ICS batteries are also capable of PSoC, hybrid, renewable energy storage application and other cycling/standby applications.

ICS series also have true front access terminal and front-access gas collection tubing for fast installation and facilitates maintenance.



Features & Benefits

- Extra high cycling and fast charge performance
- Designed for intensive cycle service where unstable grid power supply or no-grid, such as Telecom BTS, hybrid genset, renewable energy storage application
- Suit for 19" or 23" and ETSI power racks/cabinets with front terminal
- Superb security and reliability, more cost effective than nearest equivalent
- 12 year design float life at 25°C
- Wide operating temperature range -40°C to +50°C
- True front-terminal design
 - Not requiring any additional space between the top of the battery and the next shelf
 - Easy paralleling of 48V strings (on 2 or more shelves) or 2x24V strings on one shelf via cost-effective flexible cables running along front surface
 - With rotational symmetry not requiring expensive and long cables when long strings are assembled on multiple
- Easy installation and verification of gas collection tubing via twin front-access gas nipples also with easy connection over several shelves
- Fold-away handles for easy installation and removal from shelves

Drawings

12V monobloc dimensions (in mm)

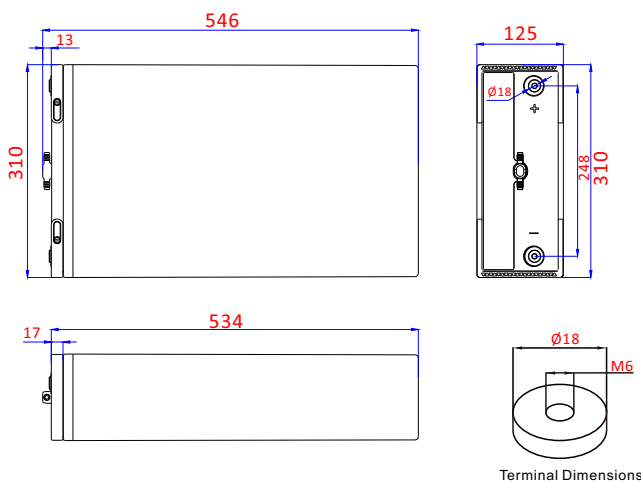

48V system: Total installation depth 546mm, including connector, bolt, insulation protective cover.

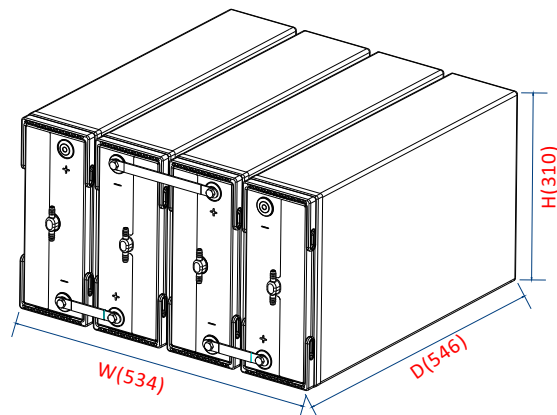

12ICS150

ICS series Intensive Cycle Service

Technical specifications

Electrical data

Nominal voltage	12 V
Number of cells	6
Rated capacity(25°C)	150 Ah - 15A for 10h to 1.80V/cell
Float voltage	2.25Vpc at 25°C
Cycle and equalize charge voltage	2.35Vpc at 25°C
Internal resistance	4.50 mΩ (acc. to IEC 60896-21)
Short circuit current	2700A (acc. to IEC60896-21)
Max. charge current	unlimited, otherwise 37.5A max. if T>25°C
Self discharge	less than 3% per month at 25°C

Mechanical data

Weight ready for use	54.7 kg (123.5 lbs)
Length	546 mm (21.5 in)
Width	125 mm (4.92 in)
Height of monobloc	310 mm (12.2 in)
Total height	310 mm (12.2 in)
Terminal	M6 female
Terminal hardware torque	8±1.0 Nm

Constant Current Discharge Characteristics Units: Amperes (25°C, 77°F)

End Voltage	5min	15min	45min	1hr	2hr	3hr	4hr	5hr	6hr	8hr	10hr	12hr	20hr	24hr
1.60Vpc	349	230	125	102	61.3	44.2	34.7	28.7	24.4	18.9	15.4	13.0	8.08	6.80
1.67Vpc	322	220	122	101	60.7	44.0	34.6	28.6	24.4	18.9	15.4	13.0	8.06	6.79
1.70Vpc	308	214	120	99.0	60.0	43.5	34.3	28.4	24.2	18.7	15.3	13.0	8.06	6.77
1.75Vpc	293	201	113	94.2	57.9	42.4	33.6	27.9	23.9	18.6	15.3	12.9	8.03	6.77
1.80Vpc	252	185	108	90.7	56.3	41.4	32.9	27.4	23.5	18.3	15.0	12.7	8.00	6.72
1.83Vpc	237	168	103	86.9	54.6	40.2	32.0	26.7	22.9	17.8	14.8	12.6	7.94	6.69
1.85Vpc	213	160	94.0	79.4	50.8	38.2	30.8	26.0	22.5	17.8	14.6	12.4	7.71	6.49

Constant Power Discharge Data Units: Watts per cell (25°C,77°F)

End Voltage	5min	15min	45min	1hr	2hr	3hr	4hr	5hr	6hr	8hr	10hr	12hr	20hr	24hr
1.60Vpc	595	404	225	187	115	84.7	67.4	56.1	48.1	37.6	30.9	26.3	16.5	13.9
1.67Vpc	551	393	223	186	115	84.4	67.0	55.8	47.8	37.3	30.6	26.0	16.3	13.7
1.70Vpc	539	384	219	183	114	83.8	66.7	55.5	47.6	37.2	30.6	26.0	16.3	13.7
1.75Vpc	516	362	208	175	111	82.1	65.8	55.1	47.4	36.8	30.2	25.7	16.1	13.6
1.80Vpc	476	347	203	171	108	80.2	64.2	53.7	46.3	36.3	29.9	25.5	16.1	13.5
1.83Vpc	394	321	198	168	107	79.3	63.4	52.9	45.5	35.6	29.3	24.9	15.7	13.2
1.85Vpc	380	311	193	164	105	77.8	62.3	52.1	44.8	35.1	28.9	24.6	15.5	13.1

NARADA POWER SOURCE CO.,LTD.

Building A, No.822 Wen'er West Road, Hangzhou, China
 Tel:+86-571-56975980 / 56975956 Fax:+86-571-56975955
 Website: www.naradapower.com E-mail: intl@narada.biz

